

Technical Data Sheet TI-B20

Spring bases for KSP Safety Brakes

- ☑ Release after minor lowering of the load without lifting
- ☑ Compensates lateral misalignments between axis guidance and clamping rod

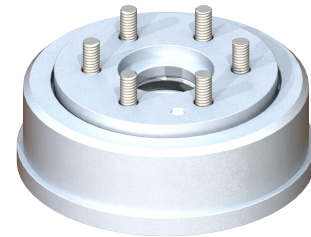

Table of Contents

1 Purpose	1
2 Advantages of a spring base	1
3 Design and function	1
4 Ordering and mounting	2
5 Mounting	2
6 Release pressure	2
7 Dimensions	2

1 Purpose

For safety reasons, the clamping system of a Safety Brake can only be released if it is not under load.

If the vertical axis of a machine overshoots after reaching its top cut-off position or moves slightly downwards for any particular reason, the Safety Brake is subjected to a partial load. In practice, this means that the load must first be raised before the clamping systems of the Safety Brake can open and before a movement in load direction is possible.

This effect, often found to be disturbing and time-wasting, can be avoided by not bolting the Safety Brake directly to the machine frame, but rather on top of a spring-base.

A spring base can compensate a minor lowering movement of the load, making it possible to release the clamping without lifting the load. The same applies for horizontal and oblique axes

The spring base also can compensate to a certain extent misalignments between axis guidance and clamping rod. No further compensating methods are required.

For more information and a simulation of a spring base, see the SITEMA website www.sitema.com and navigate to *Products, Accessories, Flanges and Spring Bases*.

2 Advantages of a spring base

Here the advantages of spring bases:

- The axis does not need to be lifted before a downward movement when minor lowering occurs during the normal cyclic operation.
- Releasing the clamping is possible in the final position of the axis.
- The spring base compensates for lateral misalignment between the axis guidance and the clamping rod. No further compensating methods are required.
- Longer service life of the Safety Brake as fewer constraint forces act on the Safety Brake.

3 Design and function

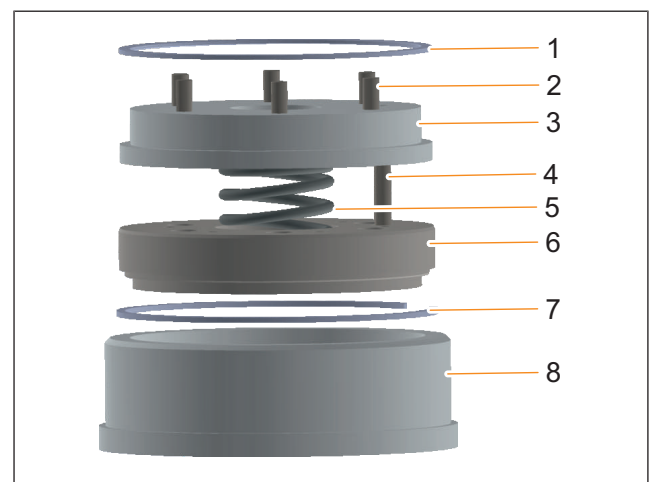

Fig. 1: Design of the spring base for the KSP series (example)

1	Retainer ring	2	Cylinder screw
3	Casing cover	4	Anti-rotation lock
5	Spring	6	Bottom plate
7	Snap ring	8	Housing

The cover (3) of the housing (8) is firmly mounted to the machine frame. The bottom plate (6) carries the Safety Brake and is firmly attached to it. If the Safety Brake is not under load, the spring presses the bottom plate against the stop. The bottom plate can move vertically (stroke h) as well as horizontally (radial play of X) against the machine frame.

If the load should settle slightly while the Safety Brake is engaged, at first only the spring force of the spring base acts on the Safety Brake. In this situation, the clamping can be released without an upward movement. If the lowering movement exceeds the stroke length h, the Safety Brake takes the full weight of the load. Now a short upward movement is required to release the clamping.

The crucial safety criterion *Safety Brake can only be released if the rod is free of load* is met.

The spring bases are equipped with an internal anti-rotation lock to prevent kinking of the hoses.

i The stroke length h of the spring base has to be added to the length of the lowering movement (for exact dimensions, see Table 1: Technical data of the spring bases for Safety Brakes). This value is important for construction and engineering safety analyses.

4 Ordering and mounting

If the spring base and the Safety Brake are ordered together, the spring base is already mounted on the Safety Brake.

All spring bases are also available as a separate product. At delivery, the spring base is fully assembled and just needs to be attached to the mounting side of the Safety Brake. (For administrative reasons, there are two items on the offer and the invoice.)

5 Mounting

There are two ways for attaching a spring base to the machine frame:

- direct screw mounting using the threaded holes and drilling patterns which correspond to the ones on the Safety Brake.
 - with a mounting flange which engages with the shoulder.
- All fastening elements which take up the load must be dimensioned to take up at least 3.5 times the admissible load M. Mounting screws are not included in the scope of delivery.

Bore holes with the correct dimensions (see Table 1) need to be provided in the machine frame.

6 Release pressure

i If a spring base is used, the release pressure for standard designs is 4.5 bar.

7 Dimensions

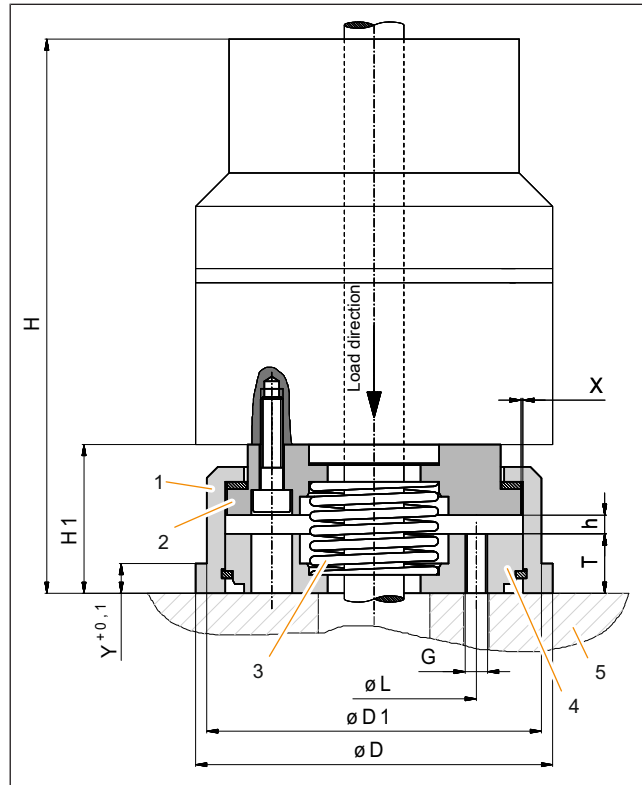

Fig. 2: Dimensions of spring bases for Safety Brakes

1	Housing
2	Casing cover
3	Spring
4	Bottom plate
5	Machine frame

Safety Brake		Spring base		H	H1	D	D1	Y	L	G	T	h	X	Wt.
ID no. (order no.)		ID no. (order no.)		mm	mm	mm	mm	mm	mm		mm	mm	mm	kg
KSP 16	KSP 016 01	FS 16	FS 016 30	149	40	96	90	8	55	6 x M6	16	5	0.5	0.8
KSP 22	KSP 022 01, KSP 022 02	FS 22	FS 022 30	184	47	120	114	10	60	6 x M6	22	5	1	2
KSP 25	KSP 025 01	FS 25	FS 025 30	192	50	140	134	10	70	6 x M8	21	5	1	2.4
KSP 28	KSP 028 02	FS 28	FS 028 30	233	60	184	178	12	80	6 x M8	29	6	1	5.8
KSP 32	KSP 032 01	FS 32	FS 032 30	278	74	216	208	14	130	6 x M10	36	6	1	10

Table 1: Technical data of the spring bases for KSP Safety Brakes

Subject to modification without prior notice